

REINFORCED CONCRETE WALL, SEE STRUCTURAL SHEETS FOR REINFORCING

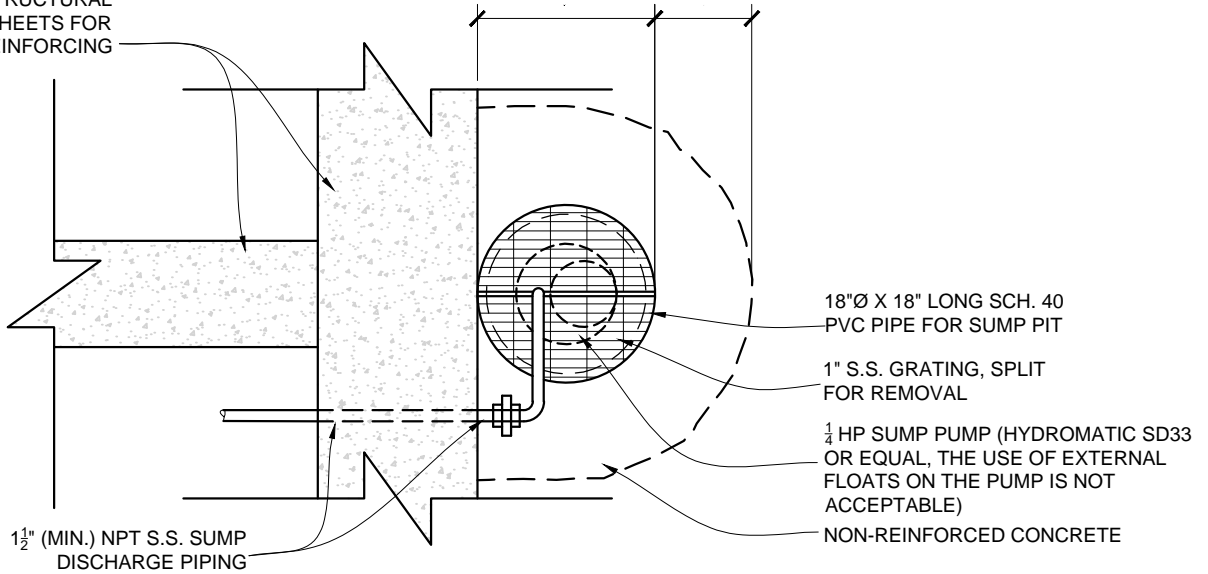

PLAN – SUMP PUMP DETAIL

NTS

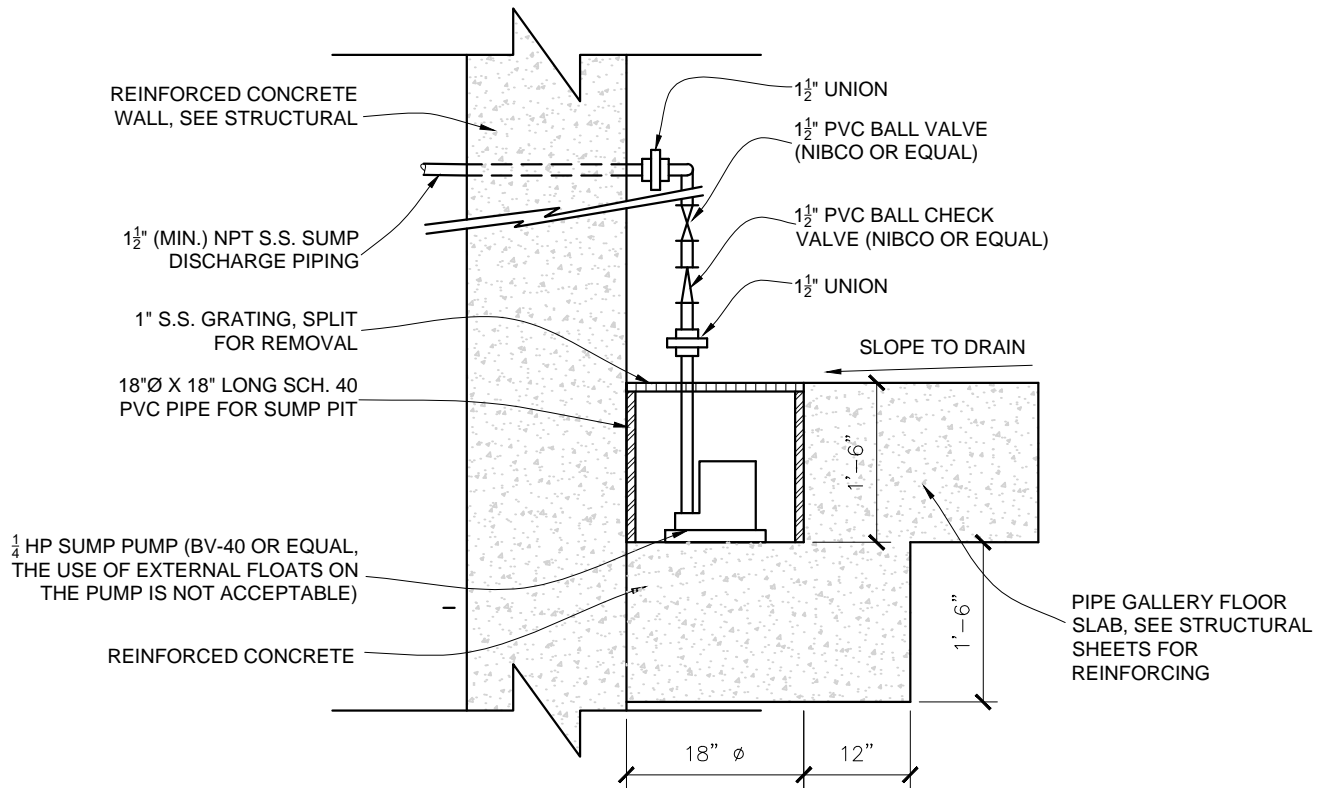

SECTION – SUMP PUMP DETAIL

NTS



STANDARD SEWAGE PUMP STATION DETAILS FOR WATER AND SEWER CONSTRUCTION