

2.5" SS PRESSURE GAUGE
W/ISOLATION DIAPHRAGM
0-100PSI RANGE

1/2" SS BALL
VALVE AND SS
PIPING

FM CONNECTION
1/2" TAPPING
SADDLE

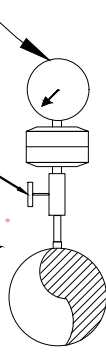

NOTE:
GAUGE/GAIRD TO BE SILICONE OIL FILLED,
TESTED, AND SHIPPED COMPLETE BY
FACTORY AS ONE ASSEMBLY.

TYP. PRESSURE GAUGE

NTS

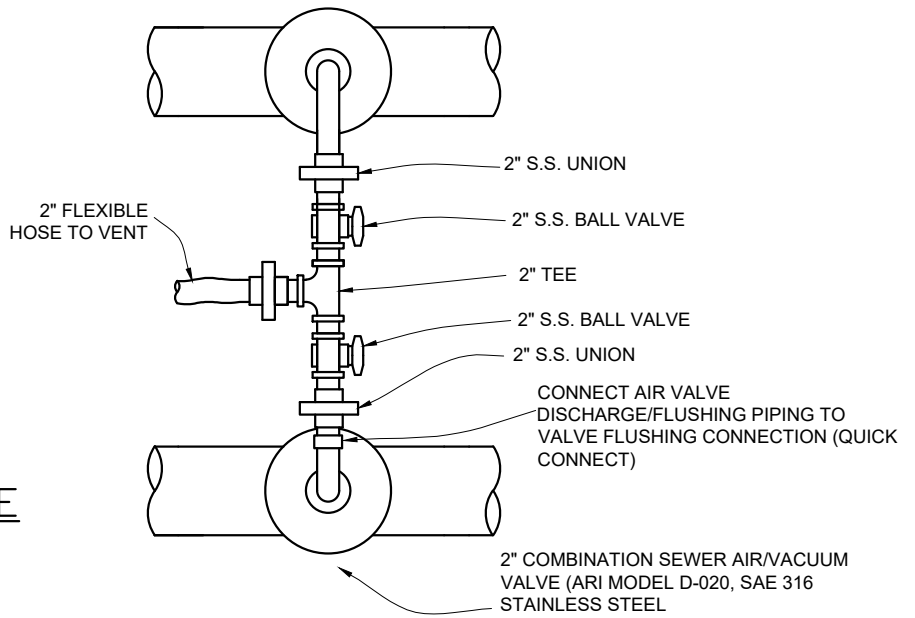

PLAN – AIR VALVE INSTALLATION

NTS

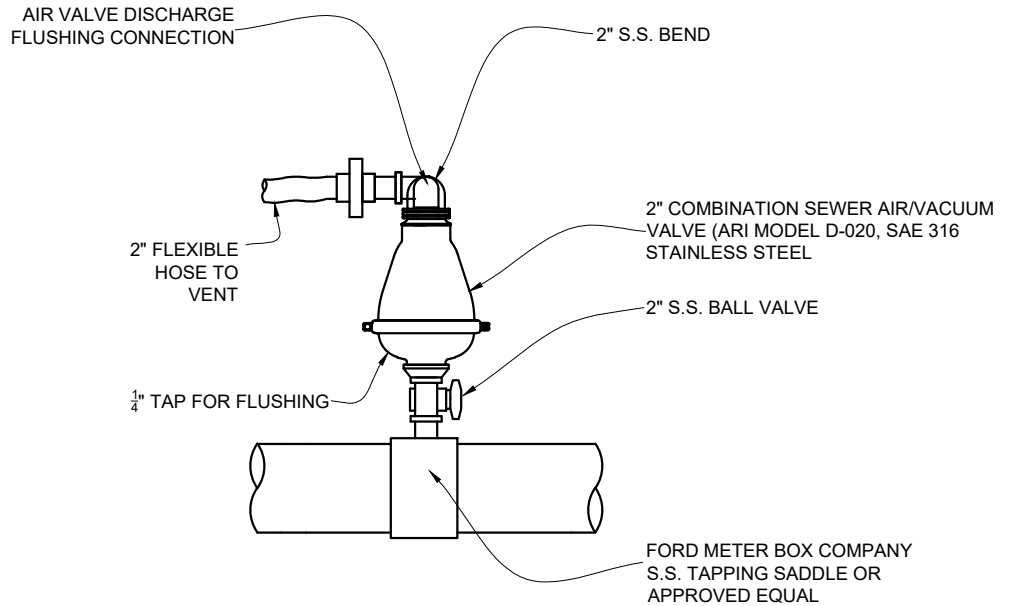

SECTION – AIR VALVE INSTALLATION

NTS



526 OAK AVENUE • P.O. BOX 769 • SPRINGDALE, ARKANSAS • 72765-0769 • (479) 751-5751

STANDARD SEWAGE PUMP STATION DETAILS
FOR
WATER AND SEWER CONSTRUCTION

DRAWN BY:
ZRA

DRAWING NO:
PS-10

DATE:
APR 2023