

SECTION THRU BOX
(WITHOUT INSULATION)

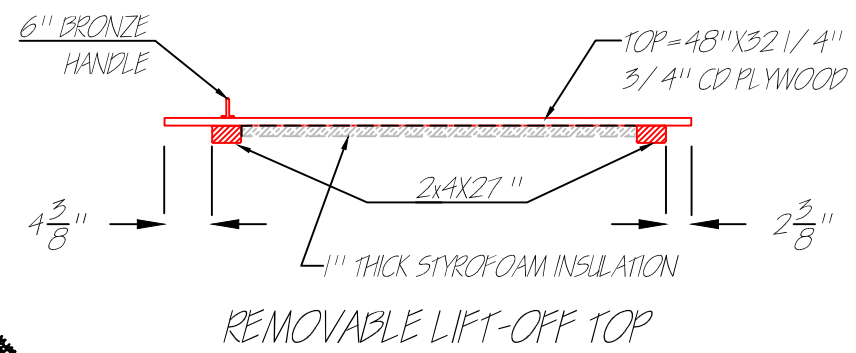

REMOVABLE LIFT-OFF TOP

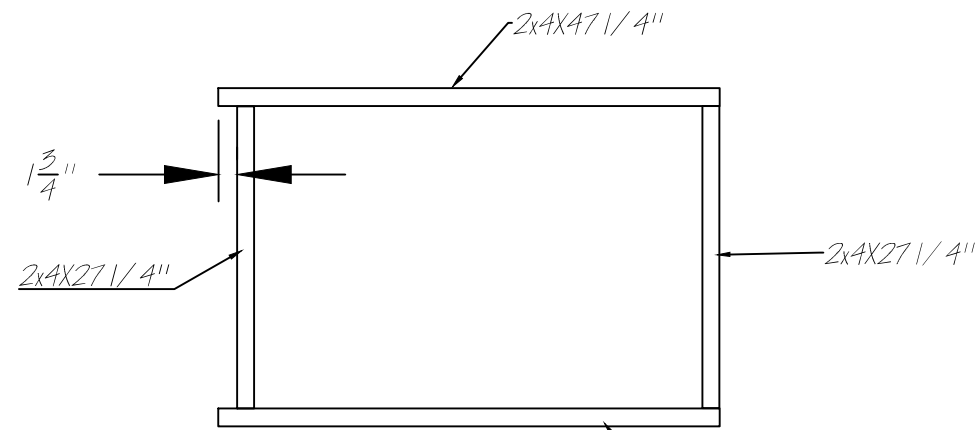

PLAN VIEW

2x4 FRAMES
(2 REQ'D.)

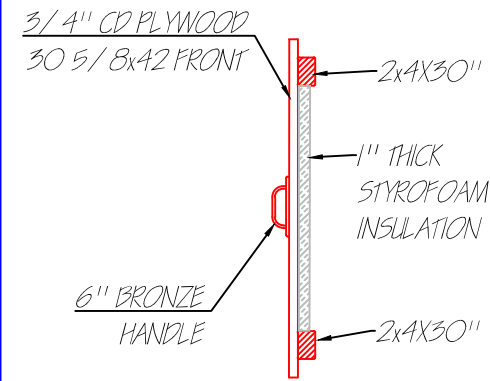

PLAN VIEW
(REMOVABLE LIFT-OUT END SECTION)

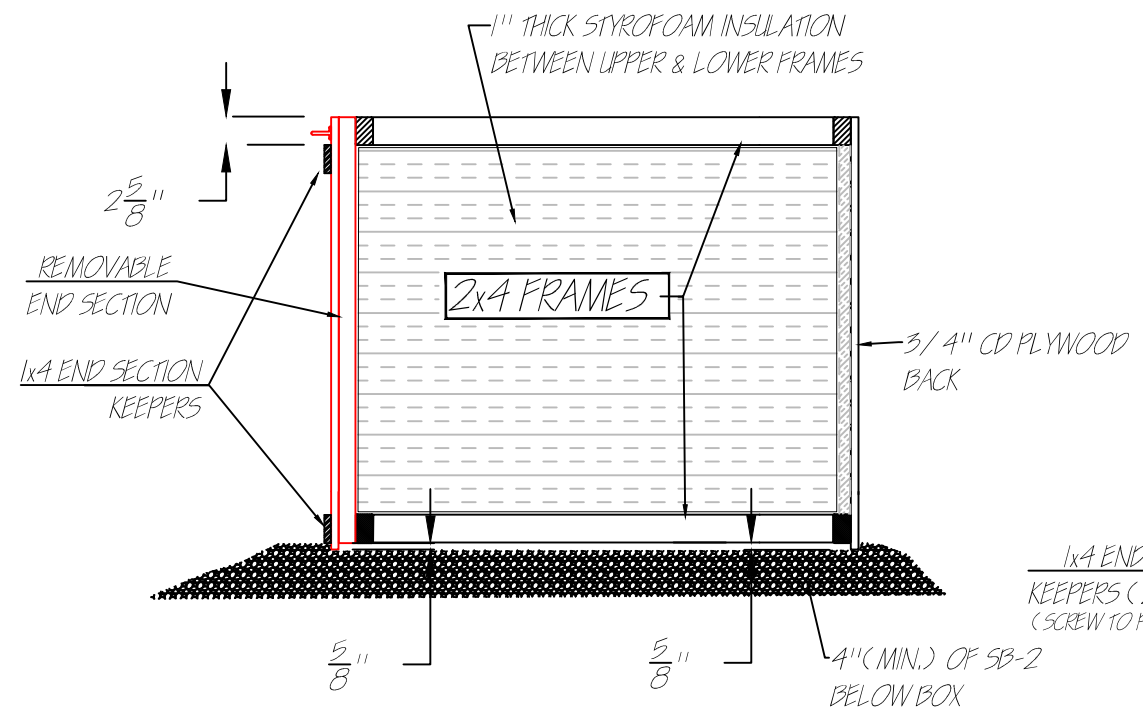

SECTION A-A
(WITHOUT TOP LID)

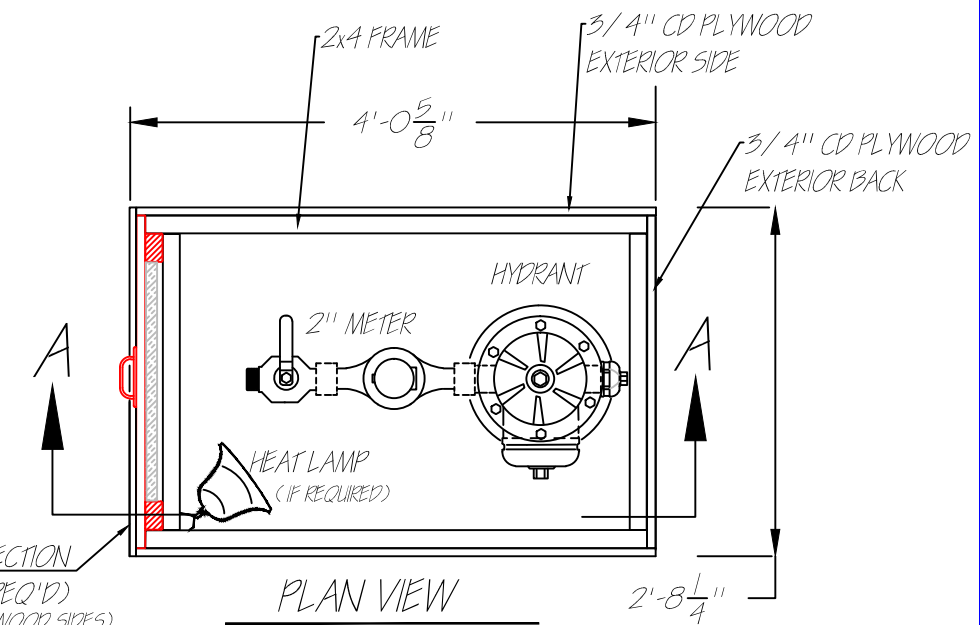

PLAN VIEW
(WITHOUT TOP LID)

FASTENERS

1. 2x4 FRAMES-3\"/>

REVISIONS	
DATE	REASON

HYDRANT HOT HOUSE FOR HYDRANT AND METER	
TYPICAL STANDARD HYDRANT & METER HOT HOUSE	
GENERAL	GENERAL
DRAWN BY LJS	CHECKED BY R
DATE 11-26-14	

SPRINGDALE WATER UTILITIES
789 (479) 751-5771

